



**LIHAITEC**  
LIHAITEC ENTERPRISE CO.,LTD.



[www.lihaitec.com](http://www.lihaitec.com)



**LIHAITEC**

LIHAITEC ENTERPRISE CO.,LTD.

TEL : 886-4-2561-0725

FAX : 886-4-2561-0726

ADD : No. 36-2, Minquan Rd., Shengang Dist., Taichung City 42948, Taiwan

e-mail: [lihaitec@gmail.com](mailto:lihaitec@gmail.com)

**otomat / Ezimill / Ezimill<sup>+</sup>**

**The best choice**

of the **automatic milling machine**

Solve the problem of staff shortage

Full automatic for milling machine easy operate.  
Module cutting function, unnecessary edit program.  
Not CNC or PC system , without G / M code.  
Friendly instinctive graphic interface.  
All graphic display , without language problem.

● STD ○ OPT. × No Function

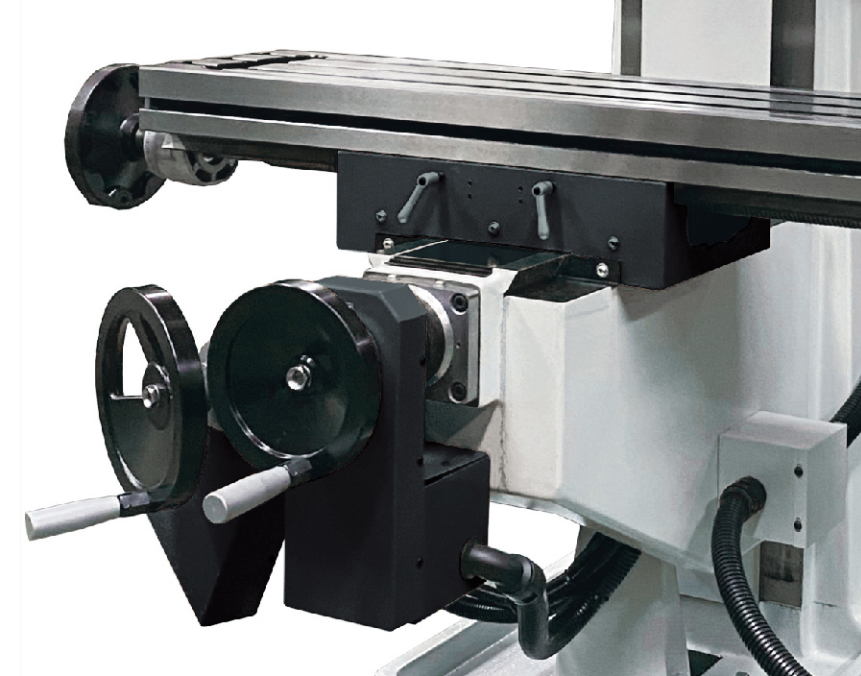

**otomat**  
Series

OT-1A  
OT-2A  
OT-3A  
OT-4A  
OT-5A  
OT-6A





**Ezimill**  
Series

SM-4AL  
SM-300AH  
SM-800H  
SM-1000H

**Ezimill+**  
Series

SM-450H  
SM-650H  
SM-1654H  
SM-2063H  
SM-2473H

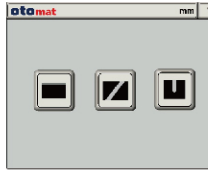
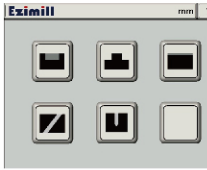
## Specification

	<b>otomat</b>	<b>Ezimill</b>	<b>Ezimill+</b>
<b>Graph</b>			
<b>Screen</b>			
<b>Function</b>	1. Conventional Milling machine function 2. Single function of Auto milling cycle: Surface / Grooving / Drilling	1. Single function of milling cycle: Pocket / Boss / Surface / Grooving / Drilling / Profile Edit	1. Single function of milling cycle : Pocket / Boss / Surface / Grooving/ Drilling / Profile Edit 2. Cycle link milling function
<b>Spect.</b>	8" Touch sreen X / Y / Z Servo motor	8" Touch sreen X / Y / Z Servo motor	10" Touch sreen X / Y / Z Servo motor
<b>Std.</b>	1. Step pulley Spindle 2. X / Y / Z Leadso rew 3. Safety hand wheel	1. Variable speed Spindle 2. MPG 3. X / Y / Z Ball screw 4. Air power drawbar 5. Auto lubrication 6. Work light 7. Coolant system	1. Variable speed Spindle 2. MPG 3. X / Y / Z Ball screw 4. Air power drawbar 5. Auto lubrication 6. Work light 7. Coolant system
<b>Opt.</b>	1. Variable speed Spindle 2. Column guard 3. Spindle guard 4. Table guard 5. Chip pan 6. Air power drawbar 7. Work light 8. Coolant system	1. Inverter Spindle 2. 10"Touch screen 3. Spindle guard 4. Portable MPG	1. Portable MPG 2. 20T ATC

## Description

	FUNCTION	<b>otomat</b>	<b>Ezimill</b>	<b>Ezimill+</b>
<b>Single Function (Auto)</b>	Pocket milling -Square/rectangle/ Pentagon/Hexagon/Octagor	○	●	●
	Pocket milling - circle	×	●	●
	Boss milling -Square/rectangle/ Pentagon/ Hexagon/Octagon	○	●	●
	Boss milling - circle	×	●	●
	Surface milling	●	●	●
	Grooving	●	●	●
	Drilling	● (single hole)	●	●
<b>Cycle Link Function</b>	Pocket milling-Square/rectangle/ Pentagon/Hexagon/Octagon	×	×	●
	Boss milling - Square/rectangle/ Pentagon/Hexagon/Octagon	×	×	●
	Surface milling	×	×	●
	Grooving	×	×	●
	Drilling	×	×	●
	<b>Aux. Function</b>	Profile line drawing edit	×	●
Z axis safety position setting		●	●	●
Rought / Finish cutting setting		●	●	●
Coolant follow with program		●	●	●
Metric / Inch display		●	●	●
Datum point position setting		●	●	●
Automatic lubrication system		●	●	●
1 / 0 Check screen		●	●	●
Portable MPG hand wheel		×	●	●
MPG Control of the program run		×	●	●
Program storage capacity (30 sets/mode)		●	●	●
USB storage		×	×	●
CAM input		×	×	×
G/ M code edit		×	×	×
<b>Accessories</b>	20T - ATC	×	×	○
	Portable MPG hand wheel	×	×	○

- Full automatic operate milling machine
- Module cutting function, no necessary edit program
- Friendly intuition graphic interface
- Stable quality and simple maintain
- Not CNC or PC base control , without G/M code
- All graphic display , without language problem

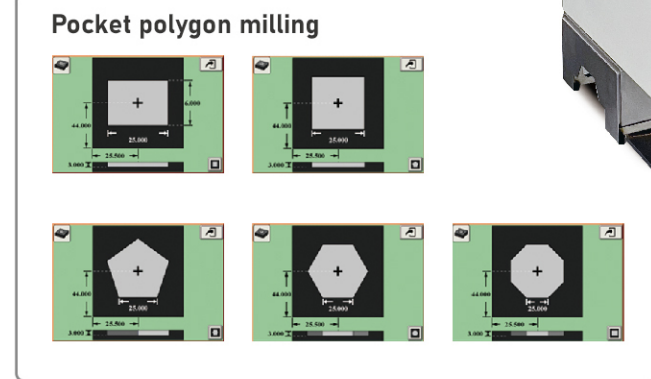
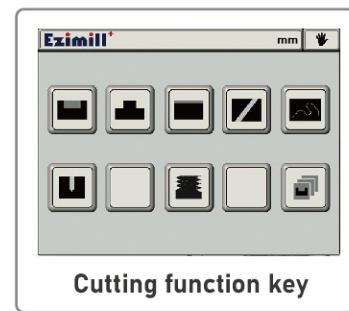

### 3 steps edit cutting program

Step 1: Set cutting dimension

Step 2: Set cutting data

Step 2: Set reference point

### STRONG AND EASY OPERATE CONTROL SYSTEM

- Simple operate interface can easy instead the conventional milling machine.
- Solve the problem of staff shortage.

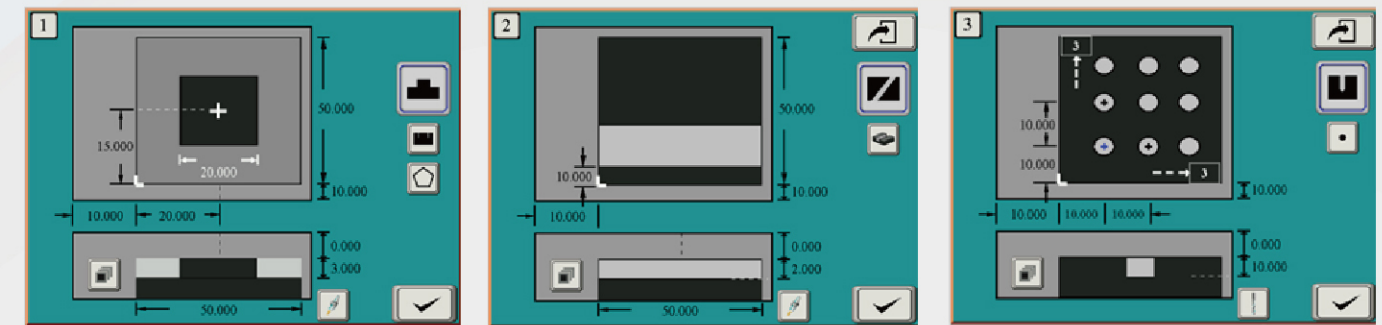
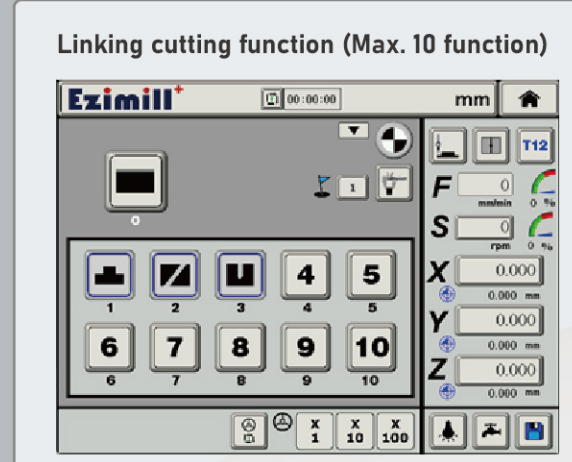

ITEM		SM-450H	SM-650H	SM-1654H	SM-2063H	SM-2473H
Table size	mm	550x400	700x450	1370x406	1600x500	1854x610
Table load	kgs	200	300	800	1500	1500
T slot (W x No.)			16mm x 3	16mm x 5	18mm x 5	
Spindle taper		BT40			BT40 / CAT40	
Spindle speed	rpm				6000	
Spindle motor	HP	5			7.5	10
X travel	mm	450	650	1000	1270	1500
Y travel	mm	350	450	500	700	720
Z travel	mm	400	550	570	600	680
X / Y / Z servo motor	HP	1 / 1 / 1			1 / 1 / 1.5	2 / 2 / 2
X / Y / Z lead screw	mm	Φ32, P5 C5			X : Φ32 ,P5 C5 Y/Z : Φ40 ,P10 C5	Φ40, P10 C5

## Servo Automatic Conventional Milling Machine

- The best partner for the automation of conventional milling machine
- Automatic milling with axial servo control system
- Maintains the operating mode of a conventional milling
- Automatic milling Surface / Groove / Drilling
- No need to install D.R.O.
- Easy to learn and use
- Touch screen

### Standard accessories

- Rubber way cover
- X / Z axis ballscrew
- Tools and toolbox
- Instruction manual
- X/Y axis auto. lubrication
- X / Z axis ballscrew
- Z axis leadscrew
- Safety handwheel

### Optional accessories

- Power draw bar
- Column guard
- Table guard
- Chip pan
- Work light
- Spindle guard
- Coolant system

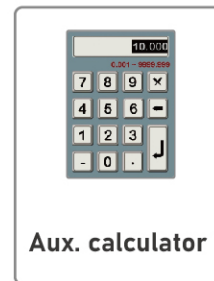
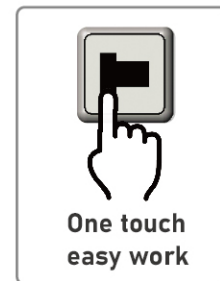
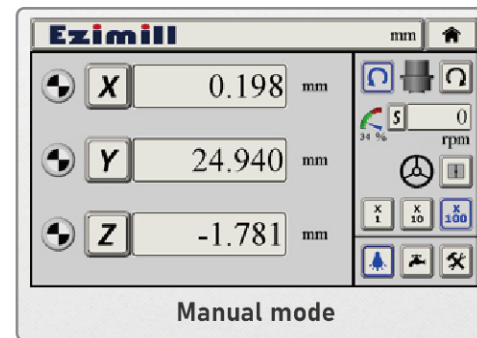
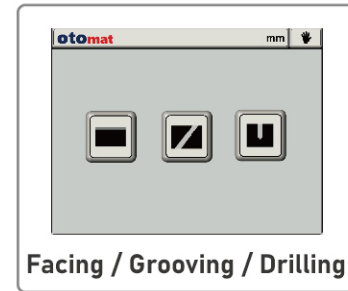

ITEM		OT-1A	OT-2A	OT-3A	OT-4A	OT-5A	OT-6A
Table size	mm	889x228	1067x228	1270x254 ( 1370x254 )			1370x305
Table load	kgs	300	350	350	400	450	
T slot (W x No.)		16mm x 3					
Spindle taper	ISO	30				40	
Spindle speed	rpm	80-2720 (60Hz)-8steps / 80-5440 (60Hz)-16steps / 60-4200 (60Hz)-variable speed					
Spindle motor	HP	3		3(5)		5	
Quill travel	mm	127					
X travel	mm	610	700	800(915)			
Y travel	mm	300	330	380	400	430	380
Z travel	mm	380	410	430	520		480
X / Y / Z servo motor	w	400/ 400/ 1kw			1kw/ 1kw/ 1kw		
Lead screw pitch	mm	5mm					

## Servo Automatic Single Function Milling Machine

- 3 axis precision ballscrew
- 3 axis servo motor
- Single function milling cutting

SM-300AH

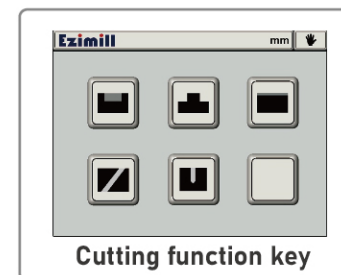

SM-1000AH



SM-4AL

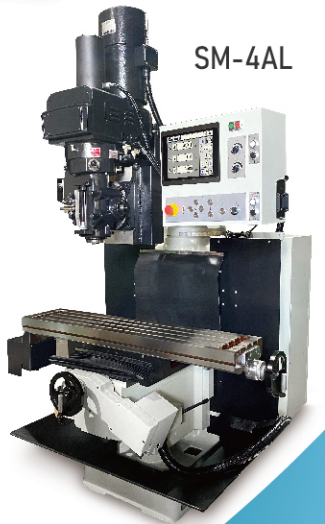

### Drilling mode

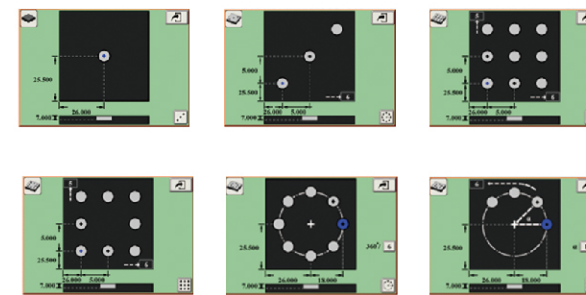

### Grooving mode

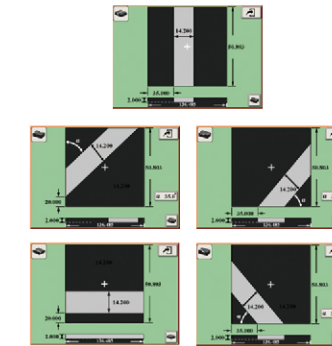

ITEM		SM-4AL	SM-300AH	SM-800H	SM-1000H
Table size	mm	1500 x 305	1270x300	1370 x 254	1524 x 305
Table load	kgs	450	500	600	600
T slot (W x No.)		16mm x 3			
Spindle taper		NT 40			
Spindle speed	rpm	70 - 4200	70 - 4000	4500	4500
Spindle motor	HP	5			
Horizontal Spindle taper		-	NT 40	-	-
Horizontal Spindle speed	HP	-	65-1500 (9steps)	-	-
Horizontal Spindle motor	KW	-	5	-	-
X travel	mm	1000	920	800	1000
Y travel	mm	380	380	460	480
Z travel	mm	403	450	560	560
X / Y / Z servo motor	KW	1 / 1 / 1.5			1 / 1 / 1
X / Y / Z lead screw	mm	Φ32, P5 C5			